

## CRYSTAL RESONATOR SPECIFICATIONS

### 石英晶体谐振器承认书

客户 Customer:	立创
型号 Product:	3TJ4
客户料号 Code No:	C5456643
我司料号 Code No:	3TJ410000NYLBC
频率 Frequency:	10.000MHz
数量 Sample Quantity:	
日期 Date:	2025-8-25

## 深圳市晶友嘉电子有限公司

SHENZHEN JINGYOUJIA ELECTRONIC CO., LTD  
深圳市龙华区东环二路数字颖博智能园 B 栋 412

TEL: 86-755-32840201 32850080  
FAX: 86-755-84269460

#### 供应商确认栏:

制作 Handler	确认 Checked	核审 Approved
戴晓嘉	陈斌	李晨

#### 客户承认栏:

承认 Checked	核审 Approved

## 1. Electrical Parameters

No.	Item	Symb	Electrical Specification				Remark
			Min.	Type	Max.	Units	
1	Nominal Frequency	F0	10.000			MHz	
2	Mode of Vibration		Fundamental				
3	Frequency Tolerance	$\Delta F/F0$	-10		10	ppm	At 25°C ± 3°C
4	Operating Temperature Range	TOPR	-40		85	°C	
5	Frequency Stability	TC	-30		30	ppm	
6	Storage Temperature	TSTG	-40		90	°C	
7	Load Capacitance	CL	12			PF	
8	Equivalent Series Resistance	ESR			60	$\Omega$	
9	Drive Level	DL	100			$\mu W$	
10	Insulation Resistance	IR	500			M $\Omega$	At 100VDC
11	Shunt Capacitance	C0			5	PF	
12	Motional Capacitance	C1				PF	
13	Aging Per Year	Fa	-3		3	ppm	First Year

## 2. Equivalent Circuit:

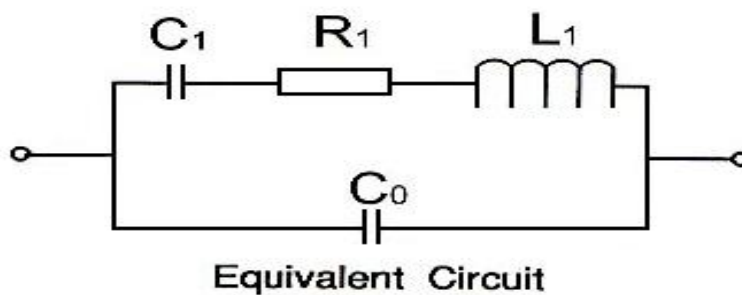

### 3.实物 Product

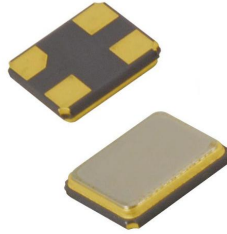

### 4.外型尺寸 Outline Dimensions (unit:mm)

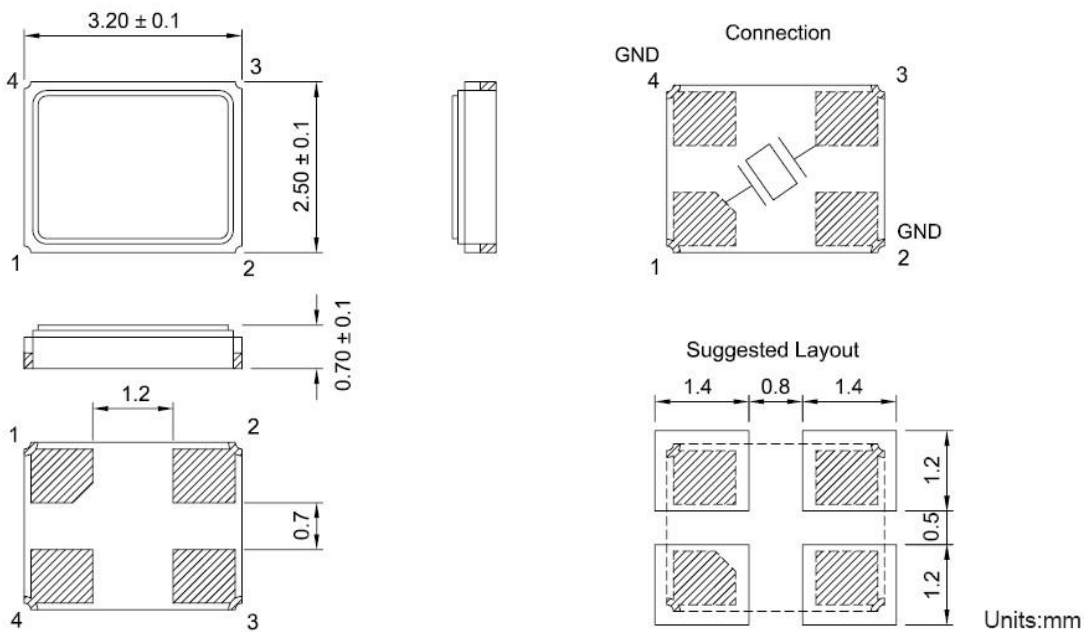

## 5.回流焊曲线 Reflow Profiles

Profiles Feature	Pb-Free Assembly
Average Ramp-up Rate (Ts max to Tp)	3°C/second max.
Preheat	
Temperature Min (Ts min)	125°C
Temperature Max(Ts max)	200°C
Time (ts min to ts max)	60~180 seconds
Time maintained above	
Temperature (TL)	217°C
Time (tL)	60~150 seconds
Peak/Classification Temperature (Tp)	
Time within 5°C of actual Peak	20~40 second
Temperature(tp)	
Ramp-down rate	6°C/second max.
Time 25°C to Peak Temperature	8 minutes max.
Suggest reflow times	3 times max.

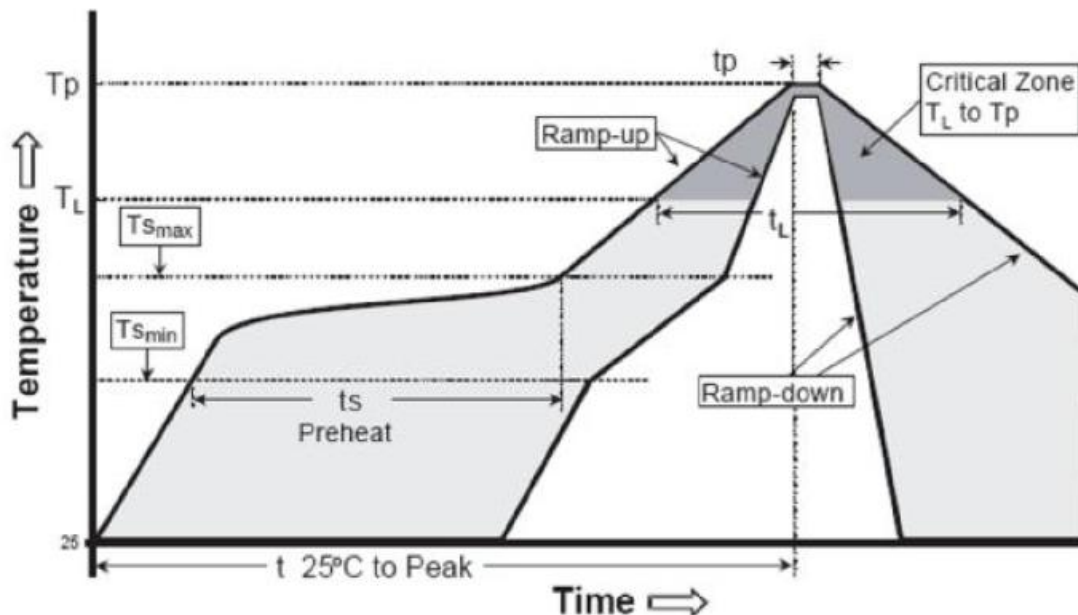



6.机械可靠/信赖性 Mechanical Performance

	Item	Condition	Standard
1.	Drop characteristics	Free drop from 50cm height on a hard wooden board for 3 times. (Board is thickness more than 30 mm.)	Frequency change: ≤5ppm Rr as specification
2..	Shake characteristics	Shake frequency 10~55Hz, cyc1~2 minutes, swing 1.5mm, direction x/y/z, all 30 minutes, test after 1 hours.	Frequency change: ≤5ppm Rr as specification
3.	Airproof characteristics	Put crystal into the pressure cabin with alcohol, keep pressure 0.4~0.5mpa 10 minutes, then take out and blow for 5 minutes	IR≥500MΩ
4.	Weld characteristics	260℃ Max, 10 seconds	90% exhibit tin ok
5.	Humidity characteristics	+40±2℃ & 90%~95% R.H. 250 hours	Frequency change: ≤5ppm Rr as specification
6.	Low temperature characteristics	-30±2℃, 250 hours, put in room temperature, test after 1 hours.	Frequency change: ≤5ppm Rr as specification
7.	High temperature characteristics	+85±2℃, 250 hours, put in room temperature, test after 1 hours.	Frequency change: ≤5ppm Rr as specification
8.	Temperature cycling	-30±3℃/30±3 min~+85±2℃/30±3min, 5 cycles	Frequency change: ≤5ppm Rr as specification

## 7.Dimension of Inside Package

内包装尺寸图

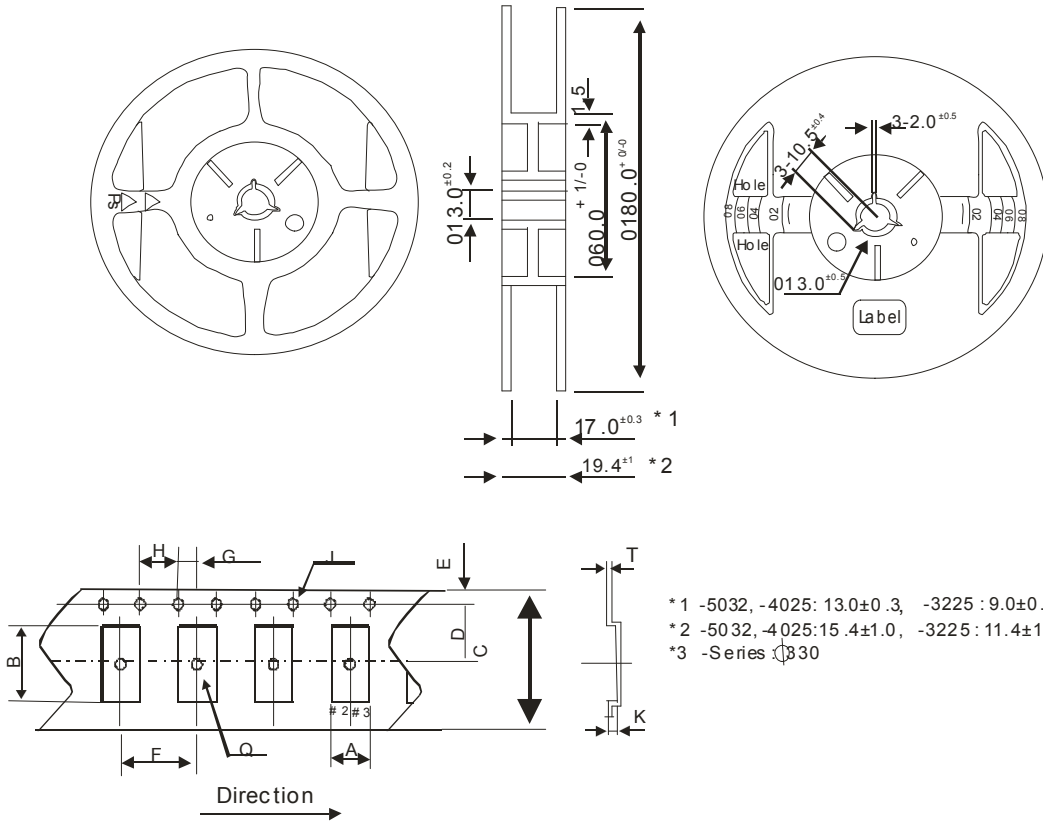

- Standard quantity of 3225 : 3.000 pcs/reel
- Standard quantity of others : 1.000 pcs/reel
- Carrier tape : Antistatic material (PS)
- Each reel can be recycled

	7050	6035	5032	3225
A	5.4 <sup>±0.1</sup>	3.9 <sup>±0.1</sup>	3.5 <sup>±0.1</sup>	2.9 <sup>±0.1</sup>
B	7.4 <sup>±0.1</sup>	6.4 <sup>±0.1</sup>	5.4 <sup>±0.1</sup>	3.6 <sup>±0.1</sup>
C	16.0 <sup>±0.2</sup>	16.0 <sup>±0.2</sup>	12.0 <sup>±0.2</sup>	10.0 <sup>±0.2</sup>
D	7.5 <sup>±0.1</sup>	7.5 <sup>±0.1</sup>	5.5 <sup>±0.1</sup>	5.5 <sup>±0.1</sup>
E	1.75 <sup>±0.1</sup>	1.75 <sup>±0.1</sup>	1.75 <sup>±0.1</sup>	1.75 <sup>±0.1</sup>
F	8.0 <sup>±0.1</sup>	8.0 <sup>±0.1</sup>	8.0 <sup>±0.1</sup>	4.0 <sup>±0.1</sup>
G	2.0 <sup>±0.1</sup>	2.0 <sup>±0.1</sup>	2.0 <sup>±0.1</sup>	2.0 <sup>±0.1</sup>
H	4.0 <sup>±0.1</sup>	4.0 <sup>±0.1</sup>	4.0 <sup>±0.1</sup>	4.0 <sup>±0.1</sup>
J	1.55 <sup>±0.05</sup>	1.55 <sup>±0.05</sup>	1.5 <sup>+0.1/0</sup>	1.5 <sup>±0.1/0</sup>
K	1.4 <sup>±0.1</sup>	1.5 <sup>±0.1</sup>	1.0 <sup>±0.1</sup>	0.9 <sup>±0.1</sup>
Q	1.6 <sup>+0.1/0</sup>	1.55 <sup>±0.05</sup>	1.6 <sup>±0.1</sup>	1.5 <sup>±0.1/0</sup>
T	0.3 <sup>±0.05</sup>	0.3 <sup>±0.05</sup>	0.25 <sup>±0.05</sup>	0.25 <sup>±0.05s</sup>

## 8. Inner carton

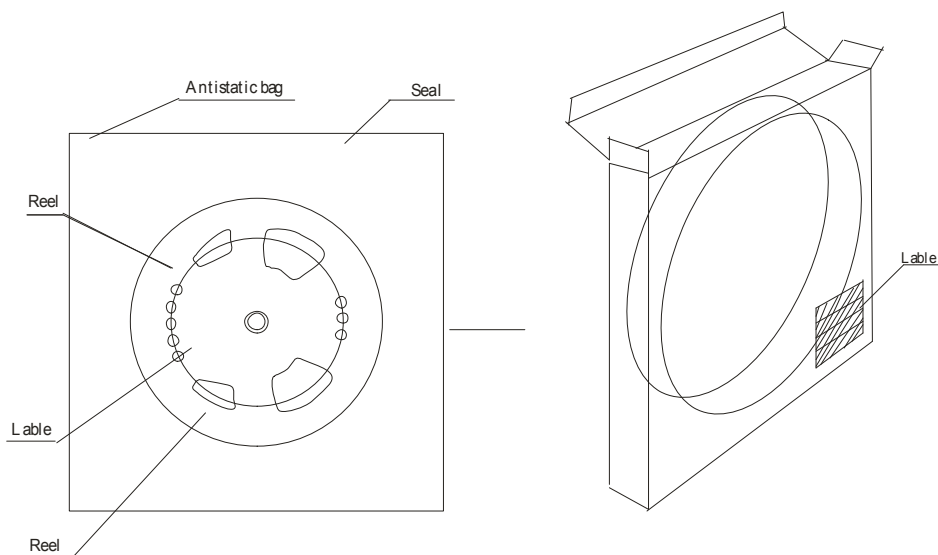

## OUTET CARTON

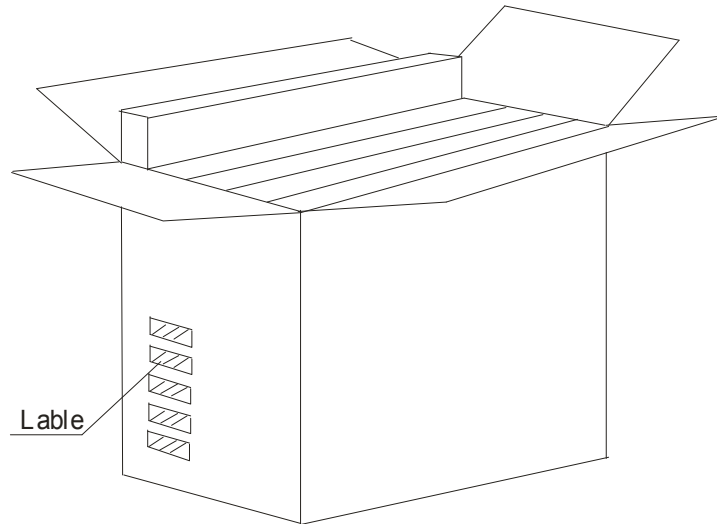

### 8-1. MARKING

- (1) Marking Labels are affixed to reel, inner carton and outer carton.
- (2) Each label contains the following information.
  - (a) Manufacture's name or aymbol
  - (b) Parts name or type
  - (c) Frequency
  - (d) Quantity
  - (e) Reel number
  - (f) Manufacturer's code (EIAJ code)

### 8-2. QUANTITY

3000pcs/reel (max.5reels in outer carton)

### 8-3. STORAGE ENVIRONMENT

- ✧ Storage the reel at normal temperature and humidity
- ✧ Open the packing just before using
- ✧ Do not expose the sun
- ✧ Do not storage with some erosive chemicals
- ✧ Nothing is allowed to put on the reel or carton to prevent mechanical damage
- ✧ Nothing is allowed to put on the reel or carton to prevent mechanical damage.

### 8-4. HANDLING

- ✧ Handle with care to prevent the damage of tape, reel and products.